



Injectable Liquid Filling with Rubber Stopping Machine

LIQFILL-40^{IR} Injectable Volumetric Liquid Vial Filling with Rubber Stopping Machine

The Automatic Twin Head Volumetric Liquid Vial/Bottle Filling with Rubber Stopping Machine Model LIQFILL-40^{IR} is suitable for Round Vials and Bottles with maximum speed of 40 Products per minute.

The Machine can give Maximum speed of 40 Vials / Bottles per minute depending on nature of Liquids, Vial/Bottle Neck Diameter, Fill Volume and Rubber Stopper size. Machine construction in fully Stainless Steel finish including machine frame structure. Machine with built-in Turn Tables at In-feed with individual drives to match the speed of Filling and Stopping for smoother operation. All parts coming in contact with Liquids and Rubber Stoppers are made from SS 316 and Teflon. Machine suitable for full as well as half stoppering.

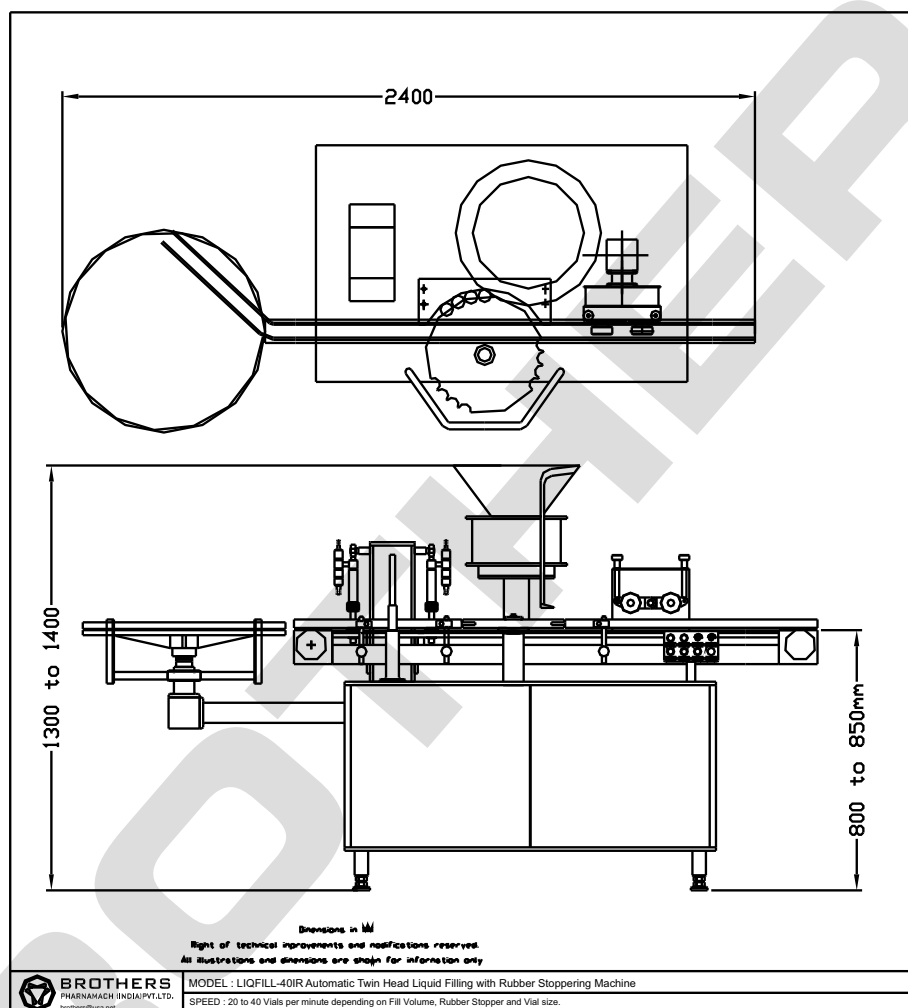

SPECIAL FEATURES :

- No Product - No Fill System, No Product - Machine Stop System
- All contact parts are made of SS 316 material with easy removal system for Auto-Claving/Sterilization/cleaning
- Machine construction in SS 304 material
- Diving Nozzle for Foam free filling
- Very High Fill Accuracy
- Automatic Infeed and Exit of Vials/Bottles including stoppering
- Minimum Change Over time
- Built-in A.C. Variable Freq. Drive System

TECHNICAL SPECIFICATIONS

Vial/Bottle Diameter : 15mm to 50mm*

Vial/Bottle Height : 75mm Maximum*

Rubber Stopper Diameter : 13mm and 20mm Dry or Wet Grey Butyl

Fill Range : 1ml to 100ml with the help of Change Parts / Syringes

Accuracy : +/- 1% Depending on Liquid, Fill volume with Single Dose

Electrical : 220 VAC Single Phase Power Supply (50 Hz)

Power : 2.0 H.P.

Speed : Max. 40 per minute

Syringe Fill Range: 0.1ml to 1ml, 1ml to 5ml, 2ml to 10ml and 10ml to 50ml and 50ml to 100ml*

Conveyor Height : 800-850 mm

Overall Dimensions : 2400 mm (L) x 850 mm (W) x 1400 mm (H)

* Specification can be changed as per customers requirements

BROTHERS PHARMAMACH (INDIA) PVT. LTD.

Plot No.2, Phase II, GIDC, Vatva, Ahmedabad 382445. INDIA
Phone : +91 79 40213213, 25831346 Fax: +91 79 40213220
+91 9825037971, 9825006052

Email : info@brothers.in mevada@usa.net Website : www.brothers.in